

**UNITED STATES OF AMERICA
FEDERAL ENERGY REGULATORY COMMISSION**

**Standardization of Small Generator
Interconnection Agreements
& Procedures**

Docket No. RM02-12-000

**SUPPLEMENTAL JOINT FILING OF PUBLIC INTEREST ORGANIZATIONS
& SMALL RESOURCE ADVOCACY GROUPS (“Small Generator Coalition”)
ON THE SMALL GENERATOR INTERCONNECTION NOPR
(October 8, 2003)**

Introduction and Description of Supplemental Joint Filing

1. In addition to the attachments which are described below,¹ the SGC organizations and companies that filed Joint Comments on October 3, 2003 wish to add the following 12 organizations to the list of groups supporting the SGC’s filed comments: **Enercon Engineering, Inc.; Equity Office Properties Trust; Ingersoll-Rand Company; Laclede Tower Association, LLC; Minnesotans for an Energy Efficient Economy; National Association of Energy Service Companies; Northeast Combined Heat and Power Initiative; Old Mill Power Company; Private Power, LLC; Solar Turbines, Incorporated; Southern Alliance for Clean Energy; & Turbosteam Corporation.**
2. The attachments, prepared to reflect recommendations made in the SGC’s Joint Comments, are offered to assist the Commission in understanding the changes proposed by the SGC and with making the appropriate modifications in NOPR documents. These attached documents are as follows:

¹ In its Joint Comments filed on October 3, 2003 in this docket, the SGC stated that it would file interconnection documents reflecting the recommendations made in the comments. See ¶ 16.

- **SGC Joint Comments – Attachment: DIAGRAMS** – Four charts that depict the diagrams described at paragraph 115 of the Joint Comments. (The diagrams attachment is a part of this document.)
- **SGC Mark-up of Appendix C (SGIP)** – Appendix C to the Small Generator Interconnection Preamble. (This is filed as separate document, “SGC-SGIP”.)
- **SGC Mark-up of Appendix 6 (Application)** – Appendix 6 to the Standard Small Generator Interconnection Procedures. (This is filed as separate document, “SGC-App6”.)
- **SGC Mark-up of Appendix 7 (SGIA)** – Appendix 7 to the Standard Small Generator Interconnection Procedures. (This is filed as a separate document, “SGC-SGIA”.)

Respectfully submitted,

[Electronically filed]

Terry R. Black for the SGC
107 Roberts Court, Alexandria, VA 22314
Phone: 703.836.9547; Email: tblack@igc.org

**UNITED STATES OF AMERICA
FEDERAL ENERGY REGULATORY COMMISSION**

**Standardization of Small Generator
Interconnection Agreements
& Procedures**

Docket No. RM02-12-000

SGC Joint Comments – Attachment: DIAGRAMS

Attached is the set of 4 diagrams described at ¶ 115 of the SGC’s comments filed October 3, 2003 in this docket. Paragraph 115 states as follows:

115. Please see the attached set of 4 diagrams. The first diagram shows the current Chart 1 in the NOPR. The second diagram shows the original diagram submitted in the ANOPR consensus document. Diagrams 3 and 4 show the technically correct chart, one where the customer owns the service transformer, and the other with the EPS operator owning the transformer. It is comparatively irrelevant which of these two diagrams is used. The first situation is more common in smaller installations such as commercial buildings, and the latter is more common with large customers such as industrial plants.

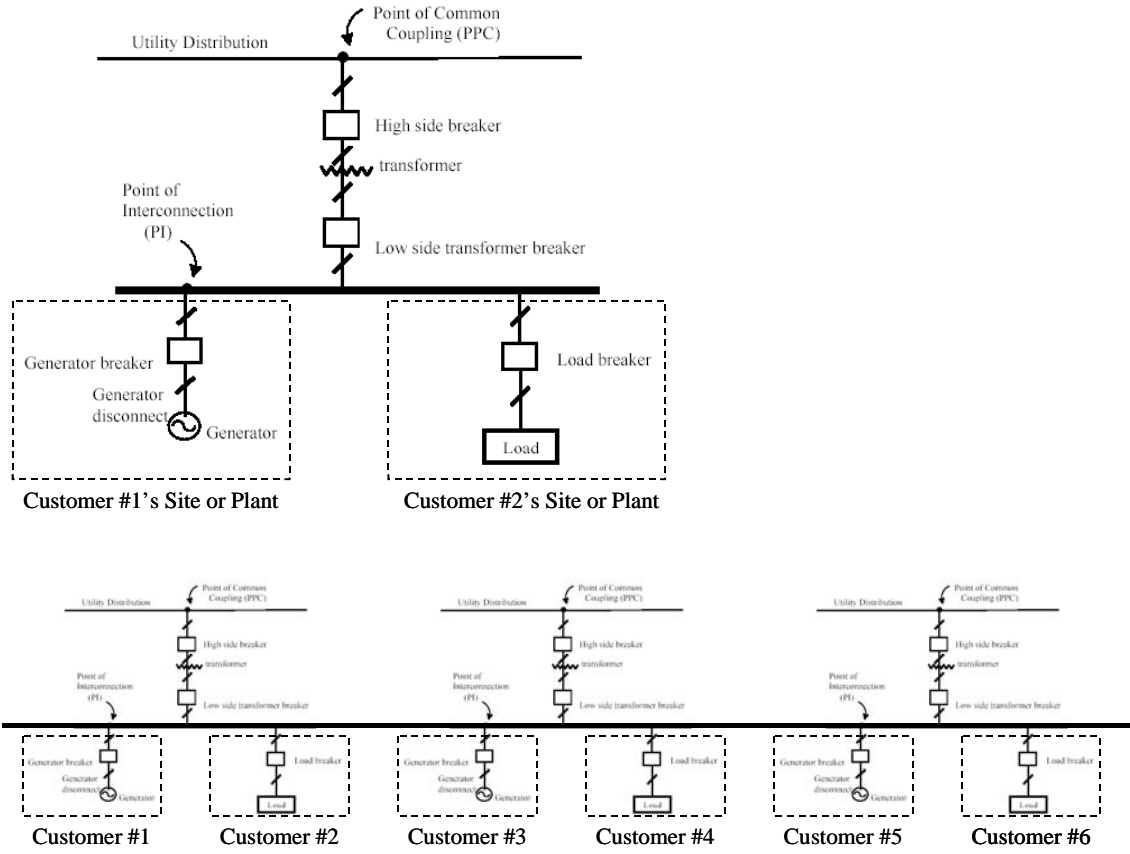

Chart 1: NOPR Interpretation

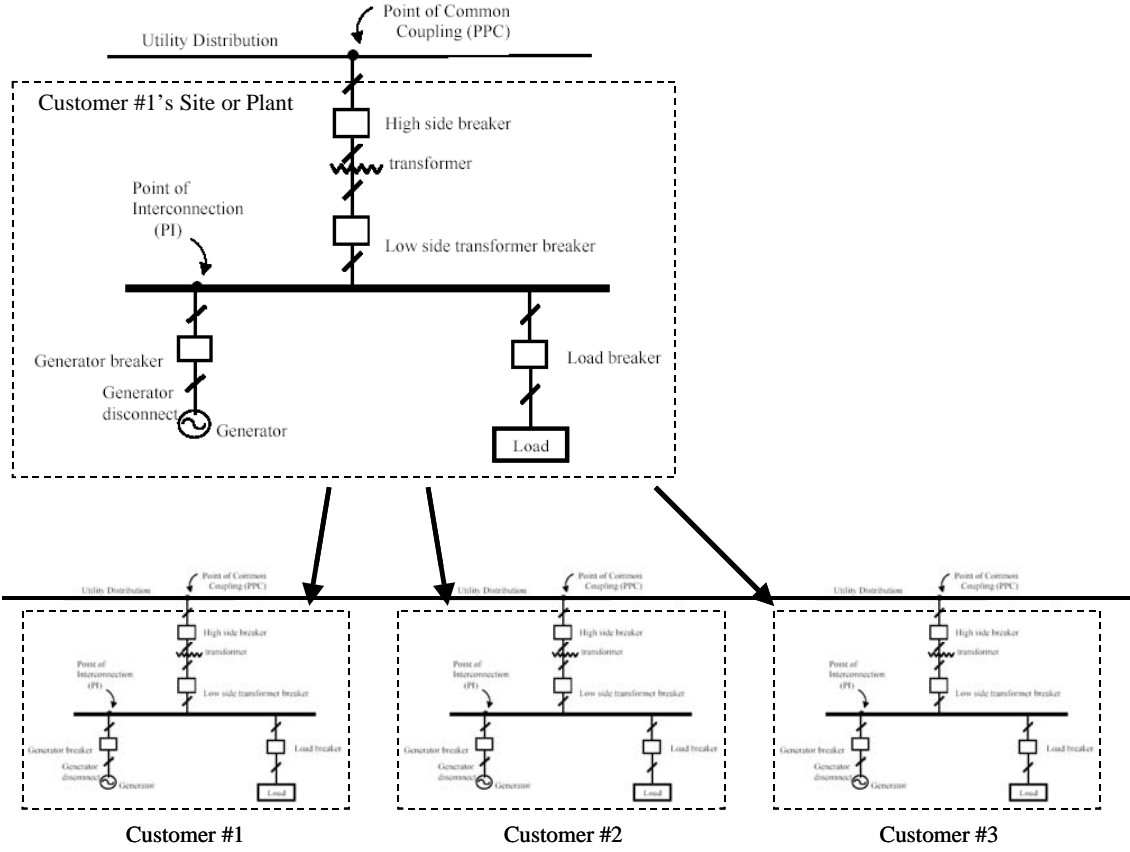

Chart 2: Interpretation Submitted In Consensus Document

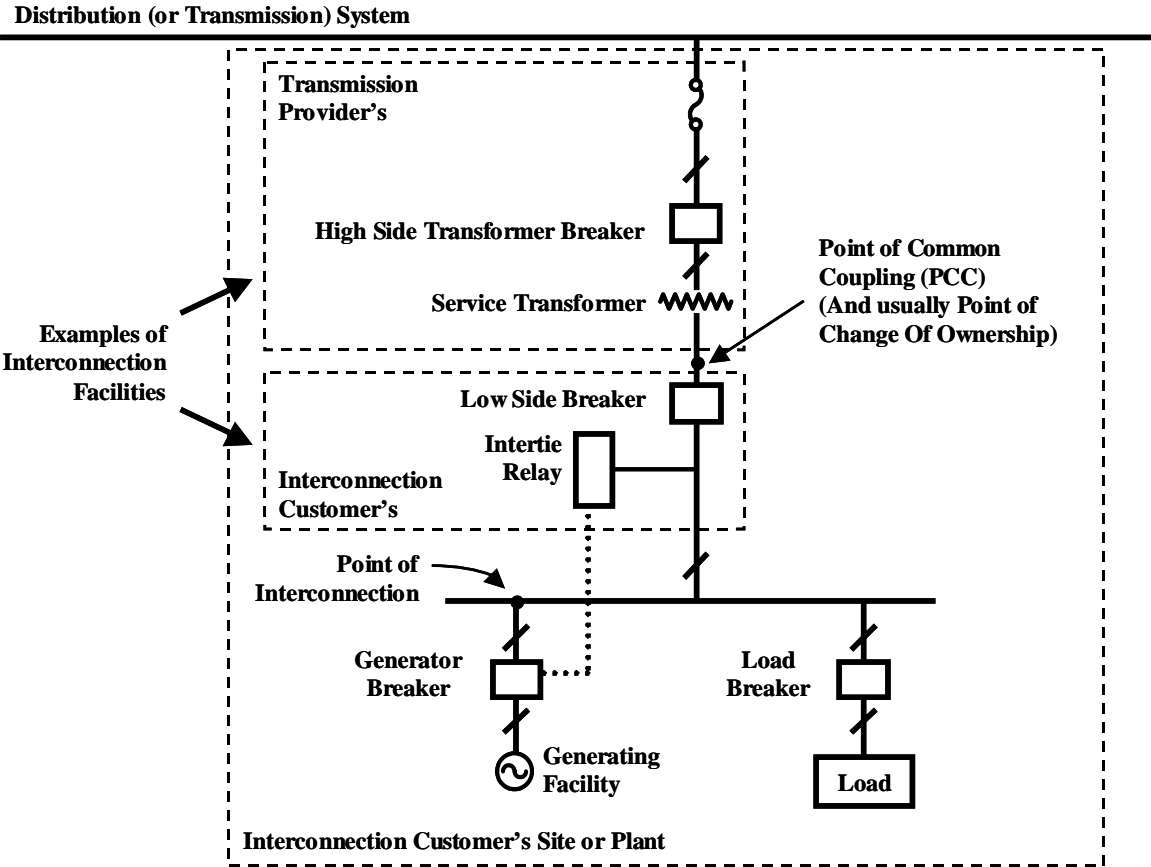

Chart 3 (corrected): When TP Owns Service Transformer

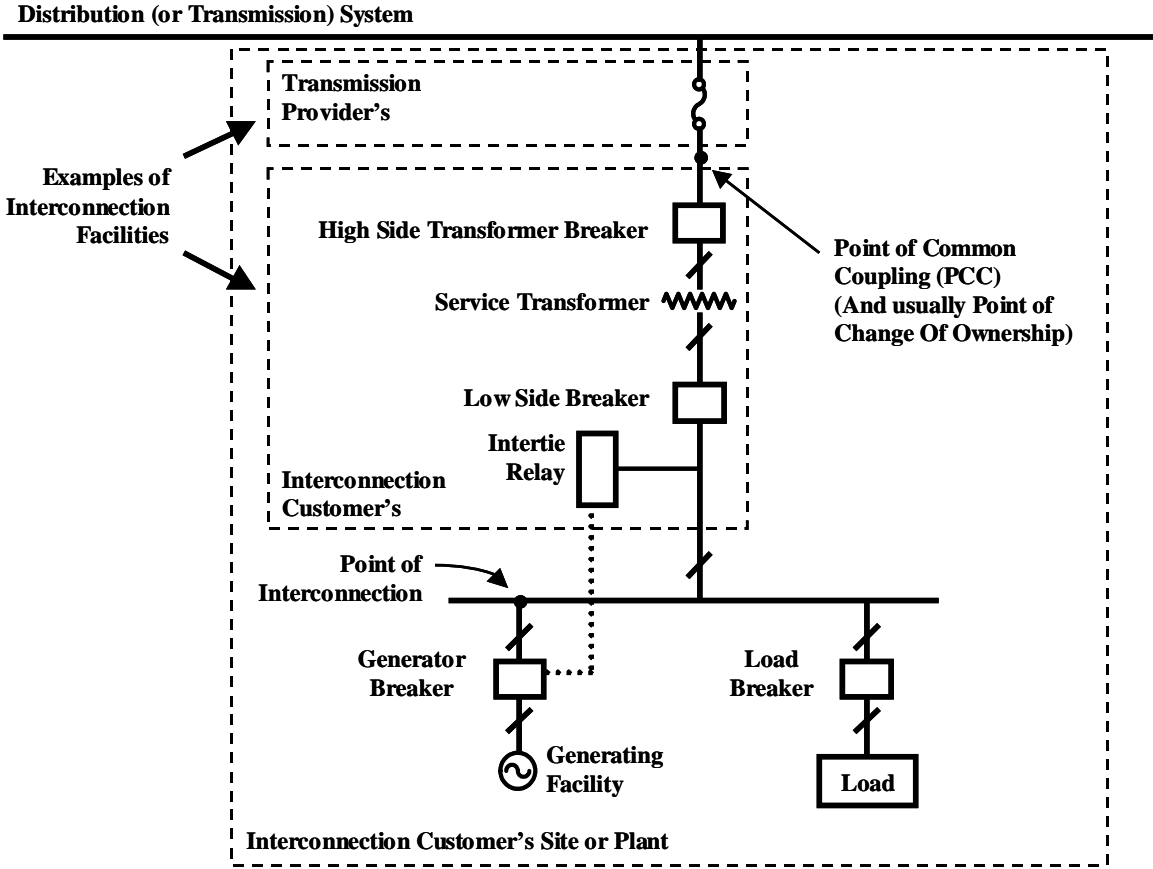

Chart 4 (corrected): When IC Owns Service Transformer